

Model Question Paper

Reg No:

Name:

RAJAGIRI SCHOOL OF ENGINEERING & TECHNOLOGY

(AUTONOMOUS)

FIRST SEMESTER B.TECH DEGREE EXAMINATION, APRIL 2021

101908/CE900C ENGINEERING MECHANICS

Max. Marks: 100

Duration: 3 hours

PART A

(Answer **all** questions, **each** question carries 3 marks)

1. Define a couple and explain its characteristics.
2. State Varignon's theorem of moments
3. Distinguish between the terms 1.Coefficient of friction, 2.Angle of friction, 3.Angle of repose and derive relationship between these terms if any.
4. Sketch the free body diagram of a ladder inclined at 30° to the horizontal floor and write the equilibrium equations considering friction at wall and the floor.
5. Find the moment about the point C (-2, 3, 5) of the force $F=4i+4j-k$ passing through the points A (1, -2, 4) and B (5, 2, 3).
6. Locate the centroid C of the shaded area obtained by cutting a semicircle of diameter 'a' from the quadrant of a circle of radius 'a' (Fig. 1).

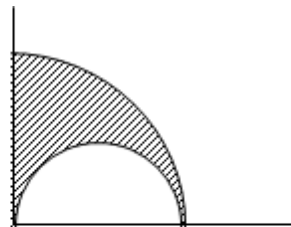

Fig.1

7. Derive the expression for the tension in the cables supporting a lift of weight 'W', when the lift is moving upward with an acceleration, 'a'.
8. A stone is thrown vertically upwards with a velocity of 20 m/s from the top of the tower 30 m height. Calculate the time required for the stone to reach the ground.
9. The radius of gyration of a flywheel, which weighs 6 kN is 50 cm. If the wheel starts from rest and attains a speed of 200 r.p.m in 2 minutes, determine the average torque exerted on the flywheel.
10. Two blocks of masses 10 kg and 25 kg are attached to the two ends of a flexible rope. The rope passes over a pulley of diameter 500 mm. The mass of the pulley is 7.5 kg and its radius of gyration is 200 mm. Determine the acceleration of the masses and the tension on either side of the rope.

PART B

(Answer **one full** question from each module, each question carries **14** marks)

11. (a) A weight Q is suspended from a small ring C , supported by two cords AC and BC (Fig. 2). The cord AC is fastened at A while the cord BC passes over a frictionless pulley at B and carries the weight P as shown. If $P = Q$ and $\alpha = 50^\circ$, find the value of the angle β . (6 Marks)

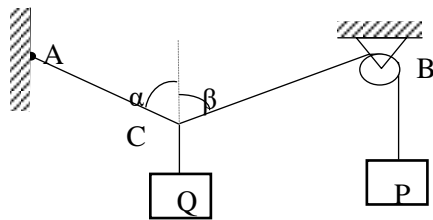

Fig. 2

- (b) A pulley A is supported by two bars AB and AC which are hinged at points B and C to a vertical mast EF (Fig. 3). Over the pulley hangs a flexible cable DG which is fastened to the mast at D and carries at the other end G a load $Q = 20$ kN. Neglecting friction in the pulley, determine the forces produced in the bars AB and AC . The angles between the various members are shown in the figure. (8 marks)

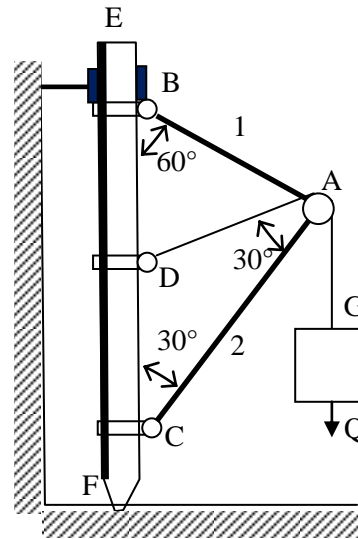

Fig. 3

12. (a) Two cylinders of weights Q and R are interconnected by a bar of negligible weight hinged to each cylinder at its geometric center by ideal pins (Fig. 4). Determine the magnitude of P applied at the center of cylinder R to keep the cylinders in equilibrium in the position shown in figure. The following numerical data are given: $Q = 2000$ N and $R = 1000$ N. (8 marks)
- (b) Two smooth circular cylinders, each of weight $W = 445$ N and radius $r = 152$ mm, are connected at their centers by a string BC of length $L = 406$ mm and rest upon a horizontal plane, supporting above them a third cylinder of weight $Q = 890$ N and radius $r = 152$ mm (Fig. 5). Find the forces T in the string and the pressures produced on the floor at the points of contact D and E . (6 marks)

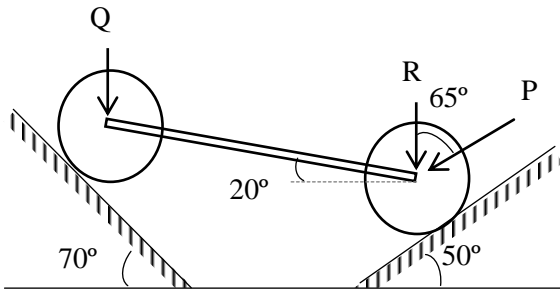

Fig. 4

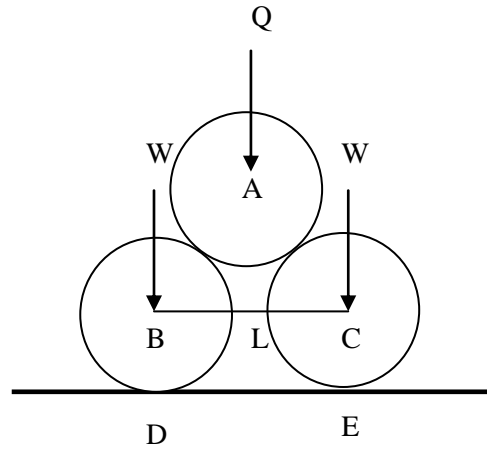

Fig. 5

Module – II

13 (a) The beam AB is hinged at A and supported at B by a vertical cord which passes over a frictionless pulley at C and carries at its end a load P (Fig. 6). Determine the distance x from A at which a load Q must be placed on the beam if it is to remain in equilibrium in a horizontal position. Neglect the weight of the beam (6 marks)

(b) Referring to the Fig. 7, the coefficients of friction are as follows: 0.25 at the floor, 0.30 at the wall, and 0.20 between blocks. Find the minimum value for a horizontal force P applied to the lower block that will hold the system in equilibrium. (8 marks)

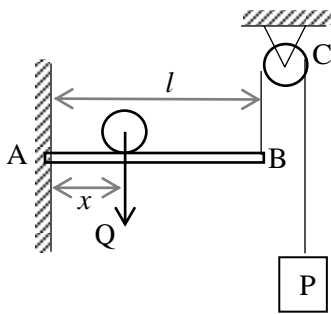

Fig. 6

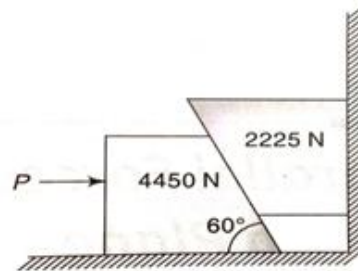

Fig.7

14. (a) A bar AB hinged to the foundation at A and supported by a strut CD is subjected to a horizontal 50kN load at B (Fig. 8). Find the tensile force S in the strut and the reaction R_A . (8 marks)

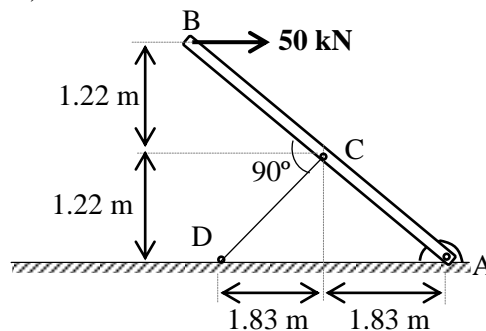

Fig.8

- (b) A uniform ladder of 4m length rests against a wall at an angle of 45° with the vertical. The coefficient of friction between the ladder and the wall is 0.4 and that between the ladder and the floor is 0.5. If a man whose weight is one half of that of ladder ascends it, how high will he be when the ladder slips. (6 marks)

Module – III

15. Determine the centroidal moment of inertia of the plane uniform lamina (Fig. 9). (14 marks)
16. A plane lamina ABCD is hung freely from point D (Fig. 10). Find the angle made by DB with the vertical. (14 marks)

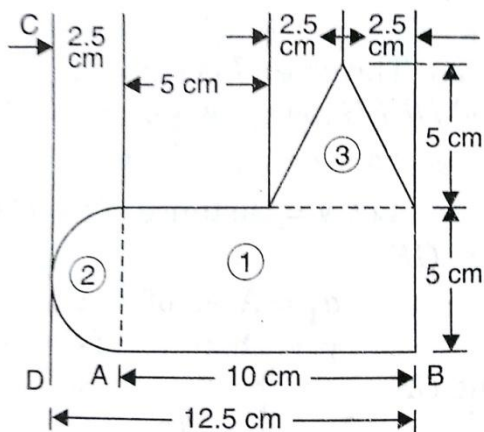

Fig. 9

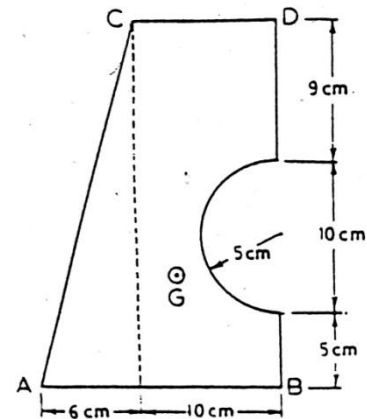

Fig. 10

Module - IV

17. The masses m_1 and m_2 are connected by a light string A over a light, frictionless pulley B (Fig.11). The axle of pulley B is connected by a light string C over a light, frictionless pulley D to a mass m_3 . $m_1 = 50$ kg; $m_2 = 40$, $m_3 = 100$ kg. Find the acceleration of the masses and the tension in the strings A and C. (14 marks)

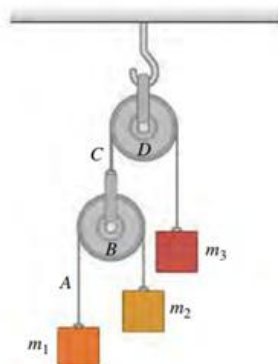

Fig. 11

18. Two bodies directly in line and 10m apart are held stationary on an inclined plane having inclination of 20° . The coefficient of friction between the plane and the lower body is 0.08 and that between the plane and the upper body is 0.05. If both the bodies are set in motion at the same instant, calculate the distance through which each body travel before they meet together. (14 marks)

Module - V

19. (a) A helical spring with negligible mass extends 0.3mm under a mass of 1.5kg and is made to support a mass of 50kg. The spring and the mass system is displaced vertically through 13mm and released. Determine the frequency of natural vibration of system. Find also the velocity of the mass, when it is 6mm below its rest position. (6marks)
- (b) A rotor of an electric motor is uniformly accelerated to a speed of 1800 rpm from rest for 5 seconds and then immediately power is switched off and the motor decelerates uniformly. If the total time elapsed from start to stop is 12.5 sec, determine the number of revolutions made while (a) acceleration (b) deceleration. Also find the value of deceleration. (8 marks)
20. (a) A wheel is uniformly accelerated from 10 rev/s to 18 rev/s in 4 seconds. The wheel continues to accelerate at this rate for the next 8 seconds. There after the wheel rotates with a uniform angular velocity. Determine the total time to complete 400 revolutions. (6 marks).
- (b) A particle with SHM, performs 10 complete oscillations per minute and its speed is 60 % of the maximum speed when it is at 8 cm from the centre of oscillation. Determine the amplitude, maximum acceleration and the speed of the particle when it is 6 cm far from the centre of oscillation (8 marks)